

new object

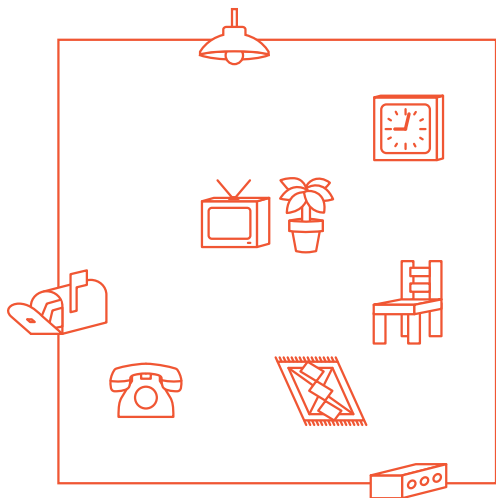

-ives

Lee Shang Lun & —
Collingwood College

new object -ives

is an invitation to play with a collection of curious artifacts.

Lee Shang Lun's work is presented alongside works created by the Year 3 and 4 students from Collingwood College.

These works have been created in collaboration with Lee Shang Lun throughout 2018 as part of their Reggio Emilia inspired Primary Art/ Performing Arts and the classroom project.

I quite like the notion of “everyday things” - the objects involved in our mundane routines and unconscious rituals. They are designed to be unremarkable, taken for granted. The moment we notice the object is the beginning of unraveling what we consider normal. Sometimes that's because of unexpected (mal)function, where the power dynamic between us and our stuff is flipped. Here, it's a wilful subversion.

New Objectives explores the relationship between the object (the play-thing) and the act of play, which is physical, social, attitudinal, and navigational in nature. The artefacts might look like readymades or reifications of modernist ideals, but their modifications and behaviors birth new interactions, from the designed and directed to the unstructured and spontaneous. I invite you to play with these everyday things and discover new objectives.

Lee Shang Lun



Lee Shang Lun has been working with the Year 3 and 4 students at Collingwood College since April on a project exploring play, games and interaction as part of the Reggio Emilia inspired Primary Art /Performing Arts and the classroom project. The students have explored physical games, instructional games, responsive games and digital games.

Throughout the project, the students have made a number of games, including board games, and physical games and the game poems, instructional games, and digital games that are a part of this exhibition.

This exhibition spans both the space here at Bus Projects and the streets that link Bus Projects with Collingwood College.

You are invited to follow the map included on the back of this catalogue to follow Adventure Road to see the students game poem posters.





new

look into the mailbox.

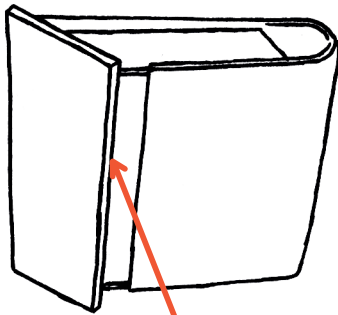

touch the plants.

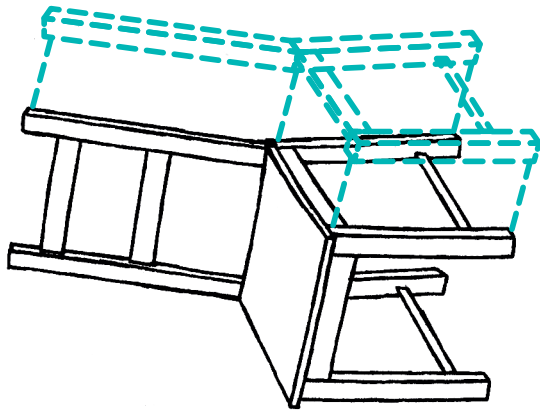

assemble the chair.

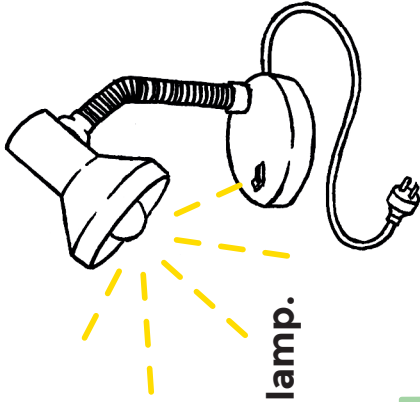

turn on the lamp.

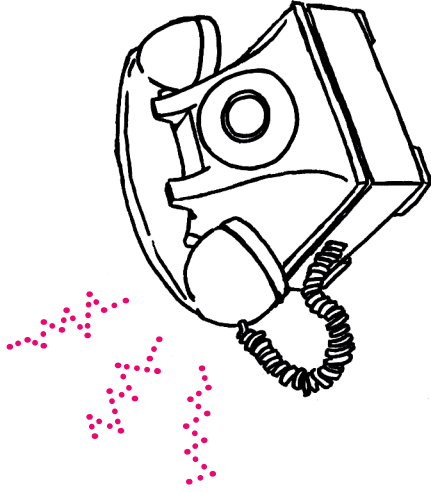

answer the telephone.

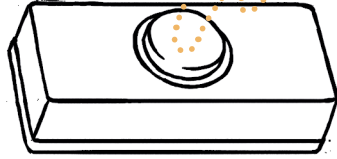

ring the doorbell.

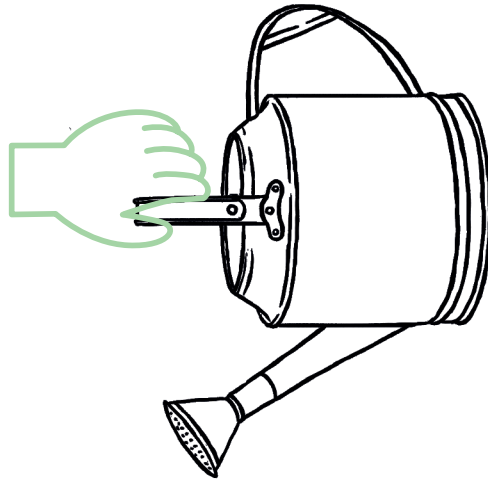

pick up the watering can.

objectives





Collingwood College students

Hani Abshir Ahmed

Jasper Frowen

Khalid Abshir Ahmed

Maryam Goolami

Turlough Ascot

Prayash Gurung

Jeremiah Barnett

Mimi Hasuoka

Caeden Beilby-McGlinn

Asha Hocker

Felix Burgess-Harman

Benjamin Holmes

Dogan Can

Livian Hunt

Zack Chalmers

Neeve Hyslop

Levia Cloud

Sundus Ismail

Shahad Elfaki

Ashanti Joy

Ikkai Esam

Alara Kurtoglu

Lucas Fitzgerald

Joseph Lam

Micah Fredman

Django Lawson

objectives

new

Jessie Martiensen

Delina Seife

Matilda McMahon

Keika Shannon

Leif Melia-Lowe

Johar Singh

Mohamed Mohamed-Bakhit

Coco Song

Khadiga Mohamed-Saeed

Lennon Taylor

Omer Mohamed-Saeed

Tauwhitu Taylor

Ferida Muhammed

Lily Thiele-Lesage

Khubaib Nurye

Zoe Tranter

Amos Orr

Leo Van Dyck

Mabel O'Sullivan

Alex Vu

Max Proghoulis Jones

Tom Wu

Sumaya Raage

Sifen Zerihun

"We enjoyed and had fun in making the games with Bus Projects and artist Lee Shang Lun. Thanks Creative Arts Victoria."

year 3/4



new

responding.

Nina Mulhall

As much as this project has been about play, it has been about responding. This has been driven not only by the Reggio Emilia inspired approach of teaching at Collingwood College, but also the nature of play and art making. It has been driven by the students own curiosity, and the collaboration between them and Lee Shang Lun in the creation of a breadth of playful artworks.

There was an openness and an eagerness to explore play from the very first “good morning” when we sat in a circle together on the art room carpet, Lee Shang Lun responding with a great big “Can everyone say good morning as loudly as possible? As quietly as possible? In another language?”

Alongside the big projects that the students have made, the board games, the videogames, and the game poems - there were constant moments of instantaneous, responsive play throughout the whole project, which to me are just as important. These moments of play, like most children’s play, were responsive to different contexts, different people, new situations, and objects. Games of make believe - families, bodyguards, fake names and fake stories that we all played along with, physical moments of play. Staring competitions and making faces at each other, who could mess each others hair up the most.



We played dancing games and copying games, where we mirrored each other's movements or tried to speak in unison. We played Tiggy - and the students changed the rules: creating new invisible barriers that couldn't be crossed, slow-motion Tiggy, animal Tiggy, the floor is lava Tiggy. Different forms of Tiggy that enabled people with different abilities - some people couldn't run as fast, or run for as long, so new rules were put in place to include them in the game. These moments of play were inspired by the physical spaces that surrounded the students. Taking note of what was around them, and who was around them, they created rules to change their interactions with those spaces and people.

Lee Shang Lun asked the students to remember these moments of play that came so naturally to them, and to question why and how they were fun or interesting, and how to express the form of play to someone else. The students (and I) learned how to translate our own natural moments of play into written, verbal, and visual instruction for other people so they could have the same experience of play as us. I witnessed these skills of creative play be honed throughout this project, and be used by the students in a directed, purposeful way towards producing outcomes.

It has been wonderful to see the students understanding of their innate ability to play blossom into something they now more deeply recognise as a tool for creating, learning, and responding.



Lee Shang Lun (李尚倫) is an antidisiplinary artist with a background in medicine, commerce, and game design. His practice explores and negotiates public performance and playfulness. His work has been exhibited at places such as the MCA in Sydney, London's Somerset House, and the Laznia Centre for Contemporary Art in Gdańsk. Shang Lun is the director of PlayReactive, a studio making bold interactive experiences, from videogames to immersive theatre. He has previously lectured at the University of Melbourne and RMIT University, and in 2013 he was the co-director of Freeplay, Australia's largest and longest running independent games festival.

Nina Mulhall is the Curator of Public Programs at Bus Projects, and helped facilitate this project. Nina has a Masters in Arts and Community Practice from the Victorian College of the Arts. She is an interdisciplinary artist, who works with communities and groups of people to collaboratively create art projects.

objectives

design by



Cecile Richard is a graphic designer, illustrator, comic artist, and maker of tiny games. Their favourite train station in Melbourne is Parliament. cecile-richard.com

We acknowledge that we are operating on the stolen lands of the Wurundjeri people of the Kulin nations. We pay our respects to Elders past, present and future and recognise that sovereignty has not been ceded.

As part of the Reggio Emilia inspired Primary program, Primary Art/Performing Arts and the Year 3/4 students' classroom project at Collingwood College, Collingwood College would like to acknowledge and thank all who participated and offered assistance towards this project including artist Lee Shang Lun, Bus Projects Gallery, City of Yarra and Creative Arts Victoria.

This project is supported by the Victorian Government through Creative Victoria.

Special thanks to our volunteers Lilli Lovegrove and Janine Tai. Thanks to our photographer Jacqui Shelton. Thanks to Collingwood College, especially Angela Dionysopoulos, Bianca Maxwell, Guillaume Desmons, Charlotte Ghaie, Sam Luck and Dale Perichon.



Bus Proj-
ects





adventure road

a poetic challenge walk from Collingwood College to Bus Projects created by the Year 3 and 4 students

